

ClarkeTM PUMP

Model - COP1B
Part No. - 6499600

**Thank you for purchasing this Clarke Hand Operated Rotary Oil Pump.
Your new pump is suitable for delivering Petrol, Oil, Kerosene, Diesel etc.**

Cast iron and steel construction for tough daily use.
Fits 48 gallon. 210 litre drums.



Pump comes complete with oil drum adapter, jubilee clip and 1.2 m of flexible delivery hose.

Specification:

Suction Distance.....	1.5m,	Flow Rate.....	22 litres/min,	Rotate Speed.	70 rpm
Gross Weight.....	4.8 kg,	Net Weight.....	4.4 kg		

CLARKE GUARANTEE

This CLARKE product is guaranteed against faulty manufacture for a period of 12 months from the date of purchase. Please keep your receipt as proof of purchase.

This guarantee is invalid if the product is found to have been abused or tampered with in any way, or not used for the purpose for which it was intended.

Faulty goods should be returned to their place of purchase, no product can be returned to us without prior permission.

This guarantee does not effect your statutory rights.

Please note that the details and specifications contained herein are correct at the time of going to print. However CLARKE International reserve the right to change specifications at any time without prior notice. Always consult the product data plate

IMPORTANT:

The use of parts other than CLARKE replacement parts may result in safety hazards, decreased tool performance and may invalidate your warranty.

PARTS DIAGRAM

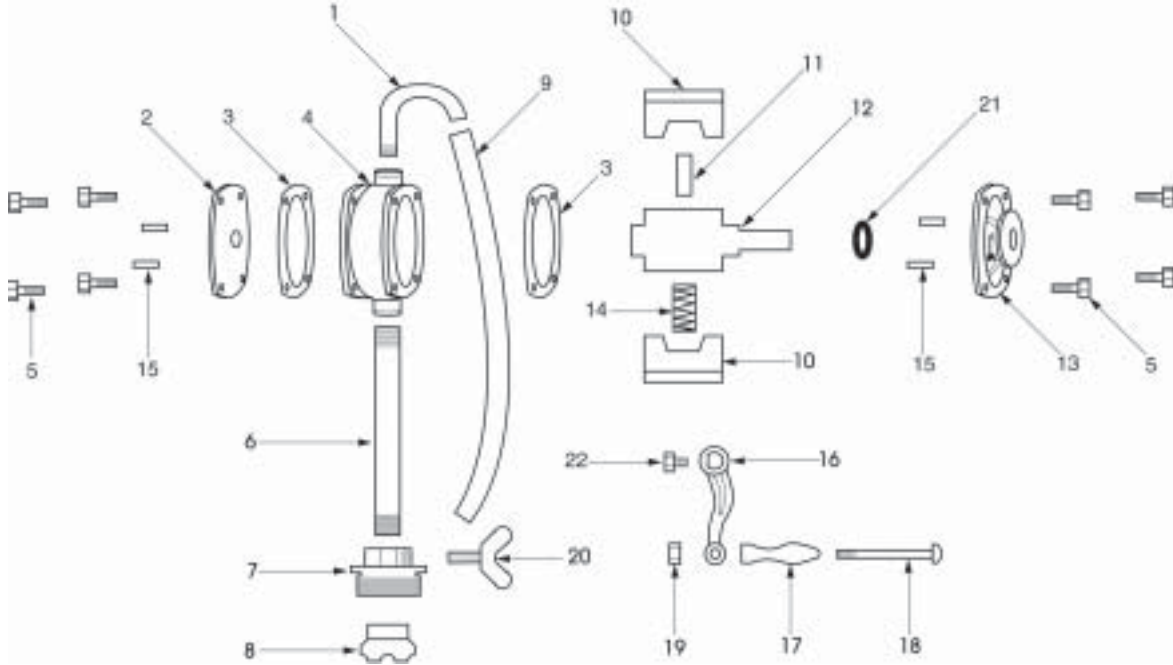

PARTS LIST

Item No.	Part No.	Description	Qty	Item No.	Part No.	Description	Qty
1	CTCOP101	Outlet Tube	1	12	CTCOP112	Rotation Unit	1
2	CTCOP102	Back Cover	1	13	CTCOP113	Front Cover	1
3	CTCOP103	Paper Seal	2	14	CTCOP114	Spring	1
4	CTCOP104	Pump Base	1	15	CTCOP115	Pin	4
5	CTCOP105	Screw	8	16	CTCOP116	Rotation Arm	1
6	CTCOP106	Inlet Tube	3	17	CTCOP117	Handle	1
7	CTCOP107	Drum Fitting	1	18	CTCOP118	Handle Pin	1
8	CTCOP108	Suction Cap	1	19	CTCOP119	Nut	1
9	CTCOP109	Plastic Tube	1	20	CTCOP120	Wing Screw	1
10	CTCOP110	Blade	2	21	CTCOP121	Seal	1
11	CTCOP111	Spring pin	1	22	CTCOP122	Nut	1

PARTS & SERVICE TEL: 020 8988 7400

or e-mail as follows:

PARTS: Parts@clarkeinternational.com

SERVICE: Service@clarkeinternational.com



Accessories

A wide range of tools and accessories are available from your nearest CLARKE dealer, for further information, contact your nearest dealer, or telephone CLARKE International Sales department on 01992 565300.